



Woody Orbit

INSTALLATION AND OPERATING INSTRUCTIONS

For other languages, download the manual, open it in Acrobat Reader and choose the desired language with the buttons on the bottom side of this page.

CONTENTS

1	GENERAL	3
1.1	Flue gas discharge.....	3
1.2	Product standards and regulations:.....	3
2	FUEL	3
2.1	What fuel can you use and what should you pay attention to?	3
2.2	Never use	3
2.3	Dry wood burns best	3
2.4	White smoke	4
2.5	Combustion air.....	4
2.6	Ash	4
3	INSTALLATION OF THE APPLIANCE.....	4
3.1	Converting the top connection to the rear flue gas duct connection.....	4
3.2	Putting the appliance in place.....	4
4	FLUE GAS DUCT.....	5
5	OPERATING INSTRUCTIONS.....	6
6	MAINTENANCE.....	7
7	GUARANTEE	7
8	TECHNICAL DATA	8
Appendix 1	DIMENSIONAL DRAWINGS AND ASSEMBLY	9
Appendix 2	DOOR CLOSED AND AJAR POSITION	11
Appendix 3	BAFFLE AND EFFICIENCY PLATE	12
Appendix 4	DIMENSIONAL DRAWING INNER PANELS	13
Appendix 5	INSTALLATION DATA, SERVICE AND MAINTENANCE LOGBOOK	14

thermoCet International B.V.
Laagerfseweg 27
3931 PC Woudenberg
The Netherlands
www.trimlinefires.com.

Modifications and printing errors are reserved.

thermoCet International BV is not responsible for any
(consequential) damage due to incorrect installation.

V201124-TG



1 GENERAL

We hope the purchase of this wood-burning appliance brings you plenty of heating pleasure. Read these instructions carefully before installing and using the appliance. Keep these instructions in a safe place. In the event of a problem with your appliance, please always provide the model and serial number, which can be found on the appliance.

Your receipt of purchase is your proof of guarantee.

The appliance is delivered complete. Check the appliance immediately after delivery to confirm that it has not been damaged during transport. If it has been damaged in any way, please inform your supplier immediately, providing as many details as possible. Your appliance has been coated with heat-resistant enamel that can withstand extremely high temperatures. Allow the appliance to burn at the highest setting and ventilate the room thoroughly during its first hours of use. As the enamel cures, a non-hazardous smell and/or some smoke may be emitted.

1.1 Flue gas discharge

Connect the appliance to a suitable individual flue gas duct that is suitable for wood-burning appliances. The appliance

must not be connected to a shared discharge system. The flue gas duct must be clean and gas-tight. Angles in the flue gas duct must never exceed 45 degrees. A T-piece with soot bag pipe must be used at the rear connection. The diameter of the flue duct must be at least equal to the connection size of the appliance. The draft in the flue must be at least 12 Pa. A flue gas damper must be used in the event of a duct drawing too strongly. Ensure the chimney is cleaned regularly. Follow the instructions of the duct supplier here. In the event of a chimney fire, extinguish the fire in the appliance (e.g. with sand), close the chimney flap if possible, and contact the fire brigade.

1.2 Product standards and regulations:

The Woody Orbit wood-burning appliance has been tested in accordance with NEN-EN 13240+A2 and also meets the following requirements:

- DIN + standard
- BimschV stufe 2
- KB – Royal Decree
- Ecodesign

2 FUEL

2.1 What fuel can you use and what should you pay attention to?

Good fuel is the “engine” of your appliance. Always use high-quality, well-dried wood. This will ensure you get the most benefit from the fire and will prevent unwanted “side effects” such as excessive smoke formation or spattering. What can you use?

- 1 Hard woods such as oak, beech and wood from fruit trees. This wood gives a short flame and burns for a longer period.
- 2 Light woods such as birch, poplar, willow, alder and spruce. These types give a long flame but burn quite quickly.
- 3 Softwood (only in a very well-burning fire in order to avoid deposits in the chimney)
- 4 Dry spruce is often used as kindling because it burns quickly.

NOTE

The appliance must be installed, connected and checked by an installation technician qualified to national, regional, local and European standards and regulations.

WARNING

Wood-burning appliances get hot when in use. After installation of the appliance, the glass surface is considered to be an active zone. The surface of the glass can become very hot! Caution! You must take all reasonable precautions such as keeping children and vulnerable people away

from the immediate vicinity of any working appliances. Furthermore, wood-burning appliances must never be installed on or against non-fireproof materials (curtains, etc.). Modification of the appliance is strictly forbidden. Never place the appliance against or in a non-fireproof wall.

2.2 Never use

- 1 Wet or fresh wood. This makes it difficult to light the appliance, and it produces little heat.
- 2 Painted or impregnated wood. The chemicals are bad for the environment and will affect the coating of the glass panel.
- 3 Coal types such as anthracite, coke or egg coal. These are only suitable for burning in a coal stove.
- 4 Printed (coloured) paper from magazines. A wad of newspapers to light the appliance is of course acceptable.
- 5 Plastic and other waste. There is no such thing as an “all burner”!
- 6 Never burn in foggy or windless weather, avoid creating a nuisance in your environment.

2.3 Dry wood burns best

The firewood must be dry. Freshly cut wood is unsuitable because it contains too much moisture (about 60%). Damp wood can be identified by hitting two logs together; wet wood will sound dull. In this case, allow the wood to dry for at least one, or even two, years. Your wood will dry well if you store it outside under a roof (not in the garage),

preferably in a sunny spot. This will allow the wind to move around it and prevent rain getting it wet. Short, split trunks dry the fastest. After drying, they only contain 15 to 20% moisture and offer the highest yield. Dry wood will produce a short, clear sound when you hit two logs together.

2.4 White smoke

Your appliance is working correctly if you can see colourless or white smoke coming out of your chimney flue. Light coloured smoke indicates good fuel with good combustion. Grey, blue or even black smoke is produced by incomplete combustion, and this can be caused by damp wood or a low temperature.

2.5 Combustion air

You probably won't notice it, but a wood-burning appliance uses about 35 cubic metres of air per hour. A sufficient supply of "fresh" air must therefore always be supplied. The external air connection (which is an added extra) can be used to ensure

a sufficient fresh air supply. In a few cases, smoke backflow can be caused by something other than poor ventilation. Perhaps the wood you are using creates strong smoke. In this case, the duct may not be able to process the quantity of flue gases. Or maybe you are burning the right wood, but the pipe or flue has an obstruction, or it narrows at some point. If you are unsure about the cause, please contact your dealer immediately.

2.6 Ash

After many hours of enjoying your fire, ash will build up. Leave the ash in the appliance for as long as possible. Only scoop it out when the ash layer starts to block the primary air holes in the front and rear combustion chamber. This should be done with a steel shovel and bucket because the ashes may still be smouldering, even after a few days. Ash from clean, dry wood is a natural product. It is an excellent "soil improver". Cooled ashes can also be placed in the GFT container.

3 INSTALLATION OF THE APPLIANCE

3.1 Converting the top connection to the rear flue gas duct connection

As standard, the appliance comes with a top connection, but this can be converted easily into a rear connection.

- 1 Remove the round back plate from the casing (break it out by moving it back and forth)
- 2 Very carefully remove the baffle plate in the appliance, **APPENDIX 3 1**.
- 3 Remove the efficiency plate at the top connection, **APPENDIX 3 2**.
- 4 Remove the cover plate from the discharge opening on the back of the appliance via the inside of the appliance.
- 5 Remove the discharge support from the top of the appliance and place it on the connection opening at the back of the appliance. Make sure there is a good gas-tight seal.
- 6 Fit the efficiency plate at the location of the rear connection with the opening facing upwards. Slide the efficiency plate downwards in the most open position; you can adjust the draft in the appliance as needed later by adjusting the plate. The latter also applies to a top connection.
- 7 Now fit the cover plate that was removed from the rear connection to the duct opening on top of the appliance, making sure there is a good gas-tight seal.
- 8 Carefully replace the baffle plate in the reverse order it was removed, and ensure that all the interior vermiculite panels are free of any tension.
- 9 Place the extra seal cover at the top of the recess in the casing.

3.2 Putting the appliance in place

- 1 Ensure the floor has sufficient weight bearing capacity for the appliance.
- 2 Make sure all the combustion air supply openings are clear.
- 3 If the appliance is placed in a situation with the discharge pipe fitted in front of a non-combustible wall, the distance between the appliance and the non-combustible wall must be at least 100 mm.
- 4 If placed against a flammable wall, the distance from the back of the appliance to the wall must be at least 200 mm.
- 5 Sufficient shielding must be used with a combustible wall if a single or double-walled discharge pipe is used.
- 6 For a flammable floor, use a fire-resistant floor plate that protrudes at least 300 mm in front of the appliance.
- 7 See image **1** for distances to flammable materials.
- 8 Make sure the right type of fire extinguishers are on hand in the event of an emergency.
- 9 Put the appliance in place in the correct position and use the adjustable feet to level the appliance.
- 10 Connect the discharge duct gas-tight.
- 11 Connect the direct external air supply to the external air connection under the appliance using non-combustible discharge material with a diameter of 80/100 mm.

APPENDIX 1 5 1 2 3

1

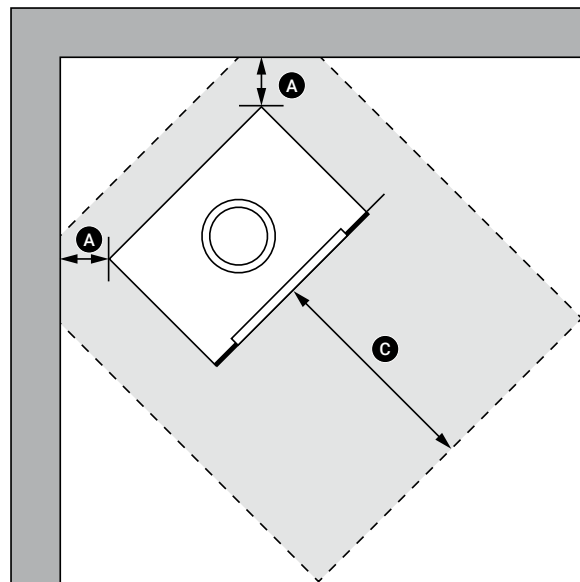
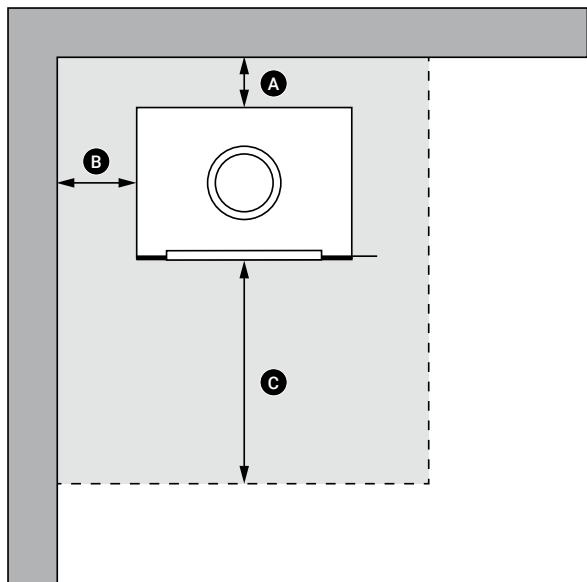

	Distance to flammable materials (mm)	Distance to non-flammable materials (mm)
A	200	100
B	300	100
C	800	800

4 FLUE GAS DUCT

The following requirements are applicable to the flue gas duct:

- 1 The flue gas duct must be inspected in advance by a specialist.
- 2 The flue gas duct must be suitable for connecting a wood-fired appliance.
- 3 The appliance must be connected to a single, undivided flue gas duct.
- 4 The flue gas duct must be clean.
- 5 The flue gas duct must be gas-tight.
- 6 The offset in the flue gas duct must not exceed 1.5 metres, with a minimum angle of 45 degrees from the horizontal plane.
- 7 For a rear connection to the appliance, the horizontal part of the flue gas duct must not exceed 500 mm. It must then go vertically upwards.
- 8 When connecting the rear connection of the appliance to a vertical flue gas duct, a T-piece with soot bag must be used.
- 9 The diameter of the flue gas duct must be at least equal to the diameter of the flue gas discharge of the appliance.
- 10 The draft of the flue gas duct must be at least 12 Pascal.
- 11 A flue gas damper must be fitted in the event of the draft being too strong.
- 12 Stove pipes must be installed with discharge towards the appliance.
- 13 The flue gas duct must be self-supporting and must not rest on the appliance.

⚠ WARNING

Before installing the flue pipe, always consult the manufacturer's installation instructions.



5 OPERATING INSTRUCTIONS

NOTE

The appliance temperature can reach very high temperatures. Use the supplied cold handle to operate the air slides and open/close the door.

Light the appliance using the Swiss method. This method requires the appliance to be lit from top to bottom. This ensures complete, clean and responsible combustion with minimal emission of dust and smoke. Proceed as follows:

- 1 If a throttle valve is fitted in the flue gas discharge, open it fully.
- 2 Move the air control slider to the fully open position, which is fully to the right. **1**
- 3 Stack the pieces of wood crosswise at a small distance from each other, from thick to thin. Stack some kindling wood crosswise on top of this. Place the firelighter at the very top. **2 1**
- 4 Then light the firelighter so the fire burns from top to bottom **2**. The wood heats up slowly, which means it will burn longer and the fire will be more controlled.
- 5 Close the door in the ajar position. **APPENDIX 2 2**
- 6 The fire will slowly draw down and ignite the large logs at the bottom of the pile. **3**
- 7 The door can now be fully closed **APPENDIX 2 1** and the control slider closed a little; for example, until the tip of the flame is level with the front of the door. **3**

NOTE

The inside of the combustion chamber can be damaged if the fire appliance is loaded too roughly.

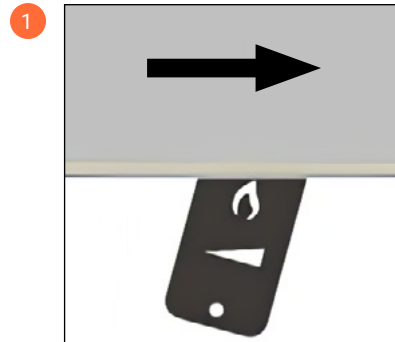

Control slider



Instructional video

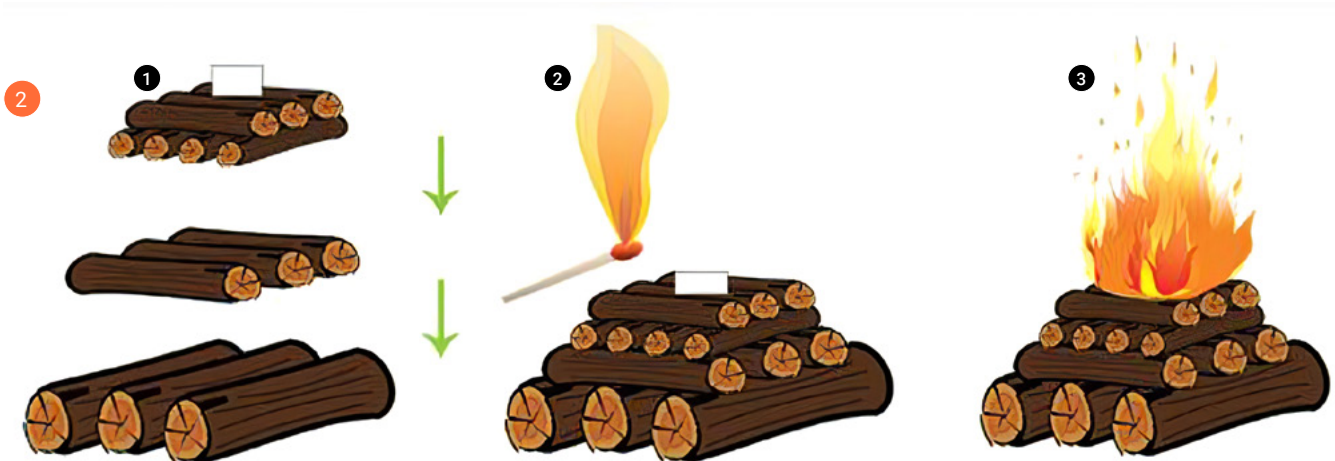

- 8 Place 2 split logs lengthwise from front to back a few centimetres apart in your appliance. (2 logs of 0.7 kg of 20 cm long each).
- 9 Close the appliance door completely again. APPENDIX 2 ①
- 10 The combustion speed can be regulated with the air slider under the door, moving it to the left results in a reduced air supply.
- 11 When the flame is controlled using the air slider and is level with the front of the door ③, the appliance is burning at its nominal combustion rate.
- 12 Fill the appliance regularly and as needed, but no more than the prescribed load, see technical data.
- 13 Never load with solid and/or liquid fuels other than dry wood.
- 14 If the ash bed becomes excessive over time (primary air openings in the front and back of the appliance are blocked), scoop out the ash.
- 15 If the draft in the appliance/chimney is too high, the draft in the appliance can be tempered by closing the efficiency plate APPENDIX 3 ②. To do this, remove the baffle plate ① by lifting it slightly at the front ①, tilting the plate ② and first removing it from the appliance using the underside of the plate ③. The efficiency plate can then be adjusted by loosening the nuts. ② ④ ⑤
- 16 If the draft is still too high when the efficiency plate is in the maximum closed position, a flue gas damper must be installed in the discharge pipe. If your appliance becomes overloaded and threatens to overheat as a result, the air supply must be closed completely. In this case, never open the door of your appliance (and certainly not in the event of a chimney fire).

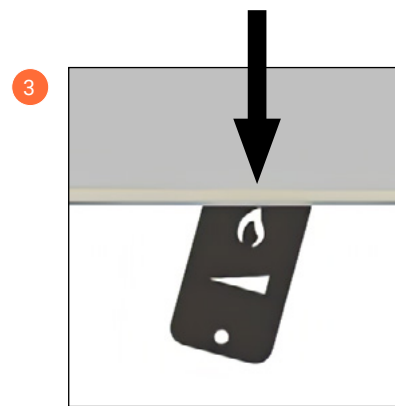

Control slider

⚠ WARNING

Treat the heat-resistant interior with care: There are vermiculite plates inside the appliance. These insulation plates ensure the temperature in the appliance remains high. The durability of the plates depends on how you stock the fire. Wet wood, for example, will cause the panel to become porous more quickly. The plate may then break if you hit it. If the plates crack after a number of uses, you can safely continue using the appliance as this has no adverse consequences for the combustion. However, if the plates swell and/or fall apart due to moisture ingress, the plates must be replaced. The plates are easy to replace. Please inform your dealer of the type of appliance and the dimensions if you want to buy a new plate.

6 MAINTENANCE

Cleaning

1 Paint

Clean your appliance with a soft, dry cloth. Do not use water, because the heat-resistant paint is not water-repellent. Do not put a vase of flowers on the appliance either.

2 Cleaning

Although the appliance has a glass panel aeration system, deposits may still form on the glass. These deposits can be removed with a glass cleaner suitable for the purpose,

which you can leave on the glass for a period to take effect if desired. Never clean the glass panel with an abrasive agent and/or abrasive sponge. These agents will scratch the paint.

3 Seals

The seals must be replaced when they become worn or damaged for optimum efficiency.

7 GUARANTEE

- 1 You have a 2-year factory guarantee. The vermiculite plates and glass are not included.
- 2 Any parts can be obtained through your dealer, please state the model and serial number.
- 3 Your receipt of purchase is your proof of guarantee.

8 TECHNICAL DATA

Appliance	Woody Orbit	
Fuel	Wood	
Loading type	Intermittent	
Nominal heat output	kW	6,4
Loading	kg/hour	1,84
Recommended log length	cm	20
Rated power min-max	kW	2,5 - 6,4
Efficiency	%	80
Emissions dust (13% O ₂)	mg/Nm ³	40
Flue gas temperature at nominal power	°C	267
Flue gas mass flow	g/s	5
CO emissions (13% O ₂)	vol%	0,072
Chimney draft minimal	Pa	12
Flue gas connection top-back	mm	150
Wood load weight	kg	1,4
Certification report no.	H/2014/0040	

Appendix 1 DIMENSIONAL DRAWINGS AND ASSEMBLY

Measurements in mm

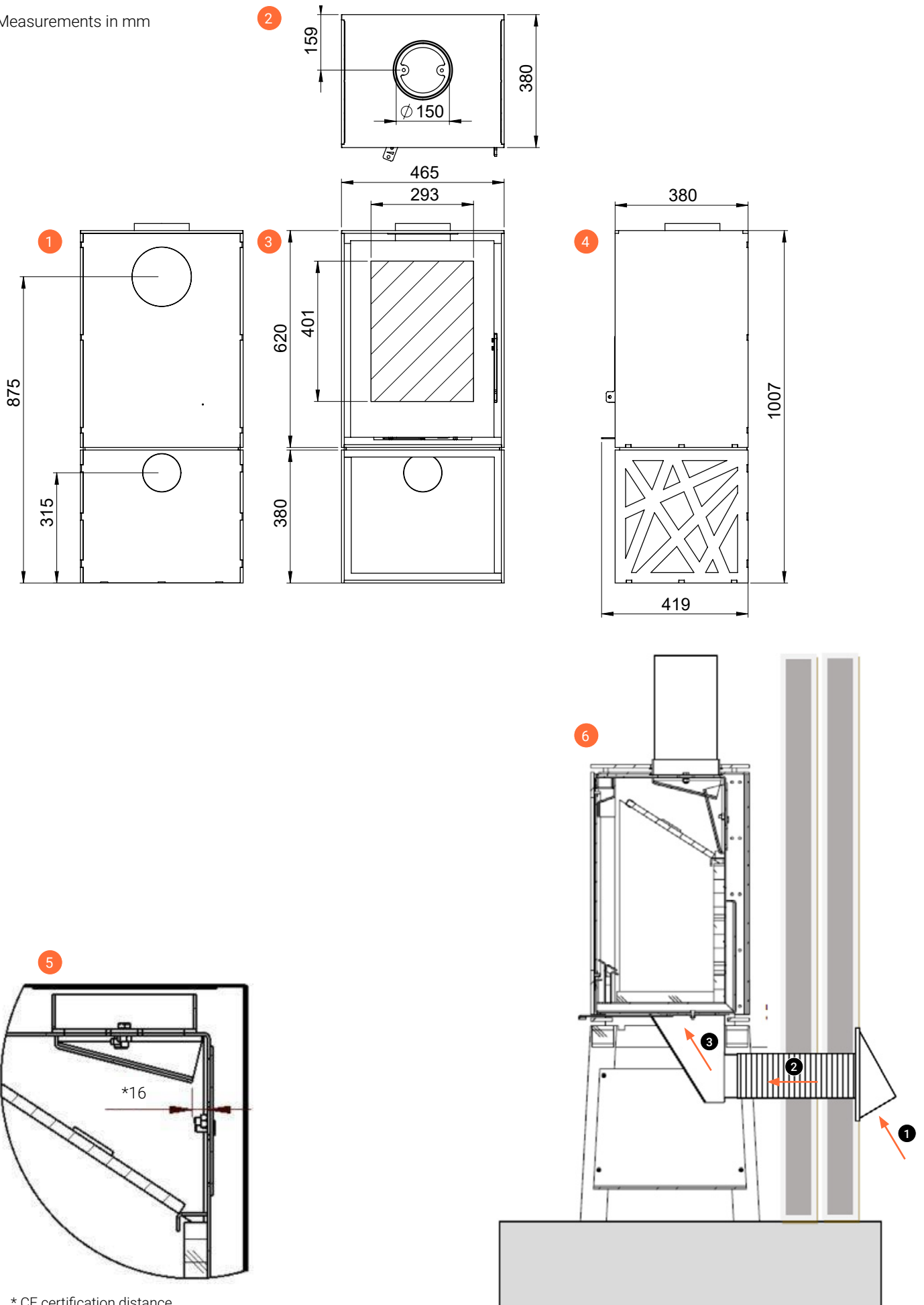

* CE certification distance



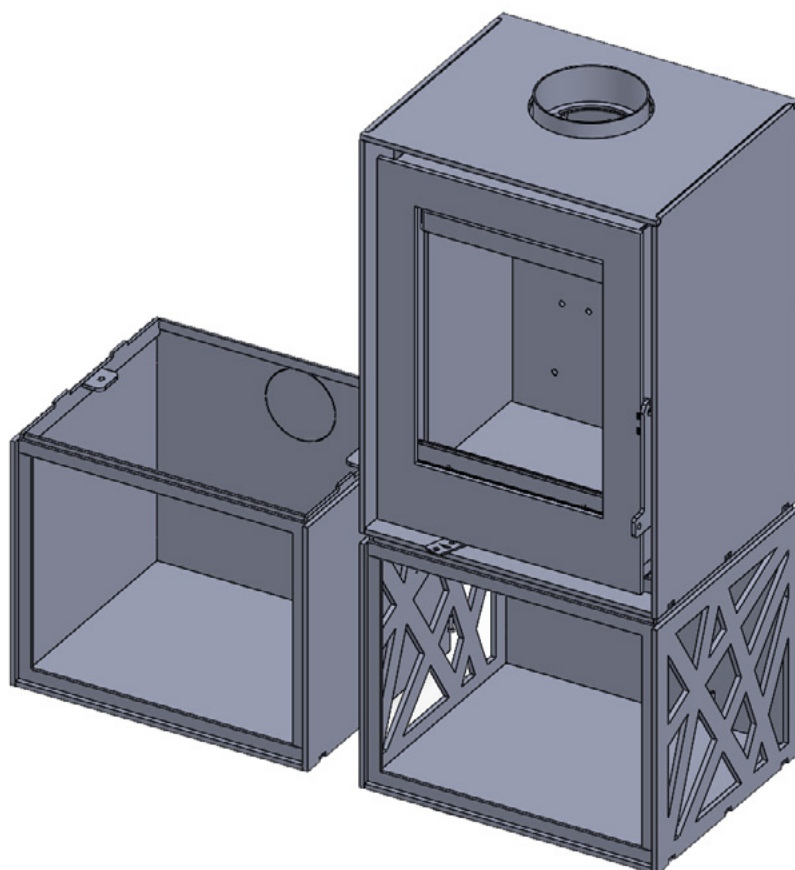
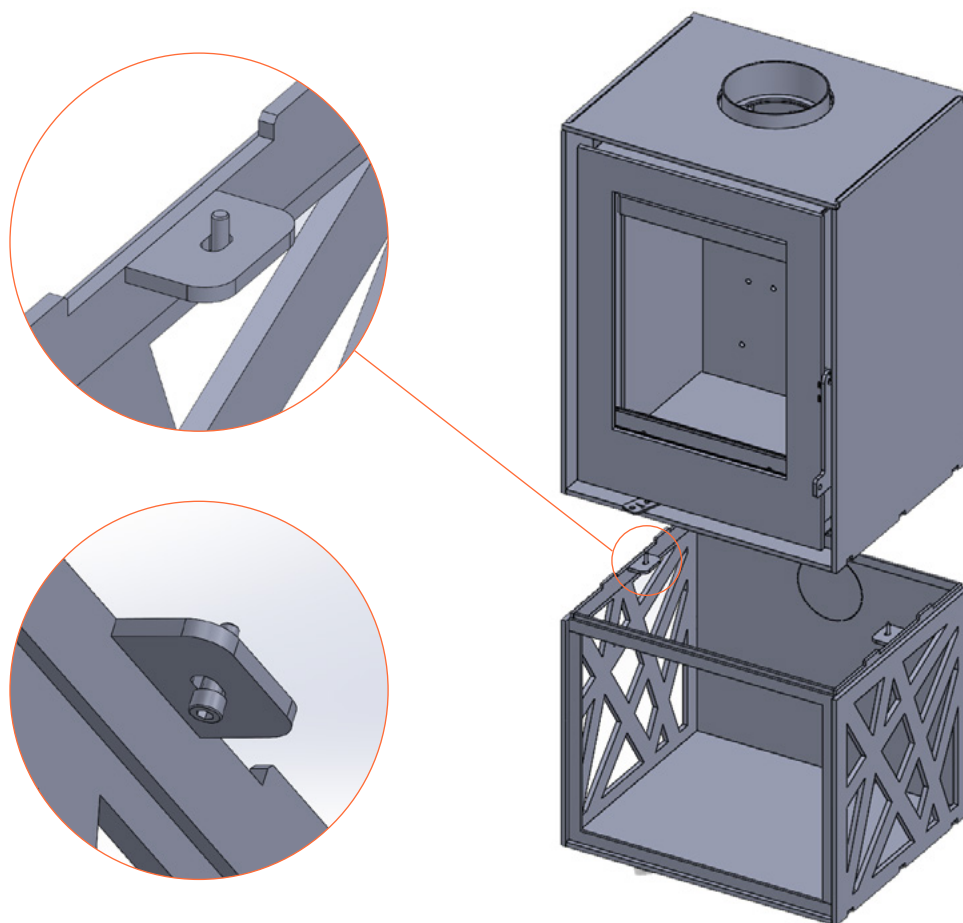

Appendix 2 DOOR CLOSED AND AJAR POSITION

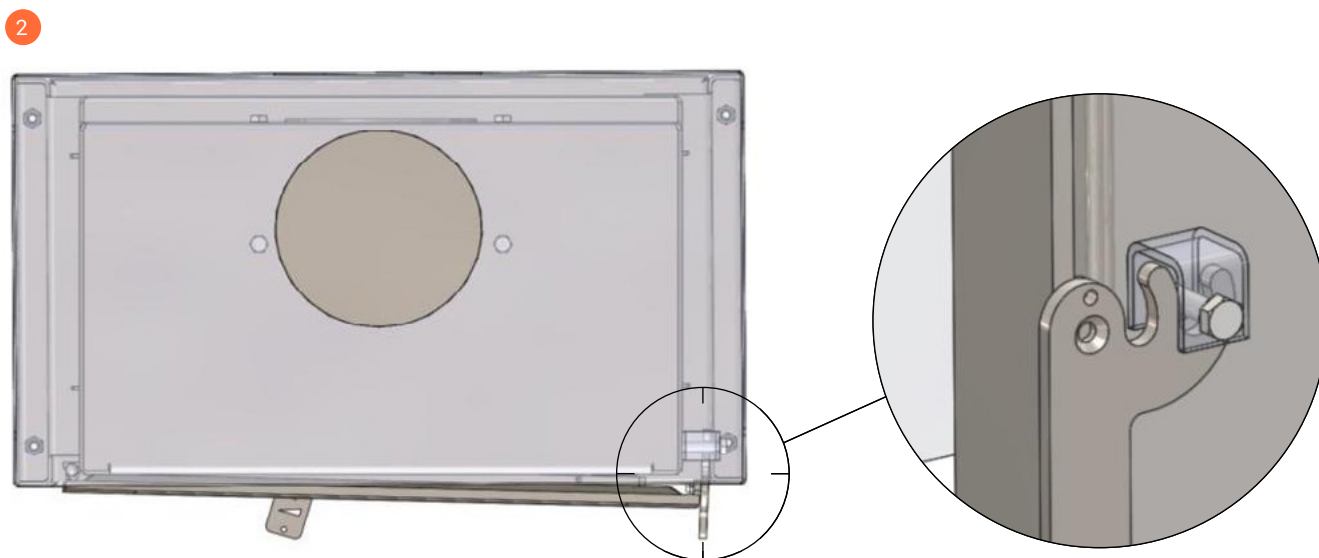
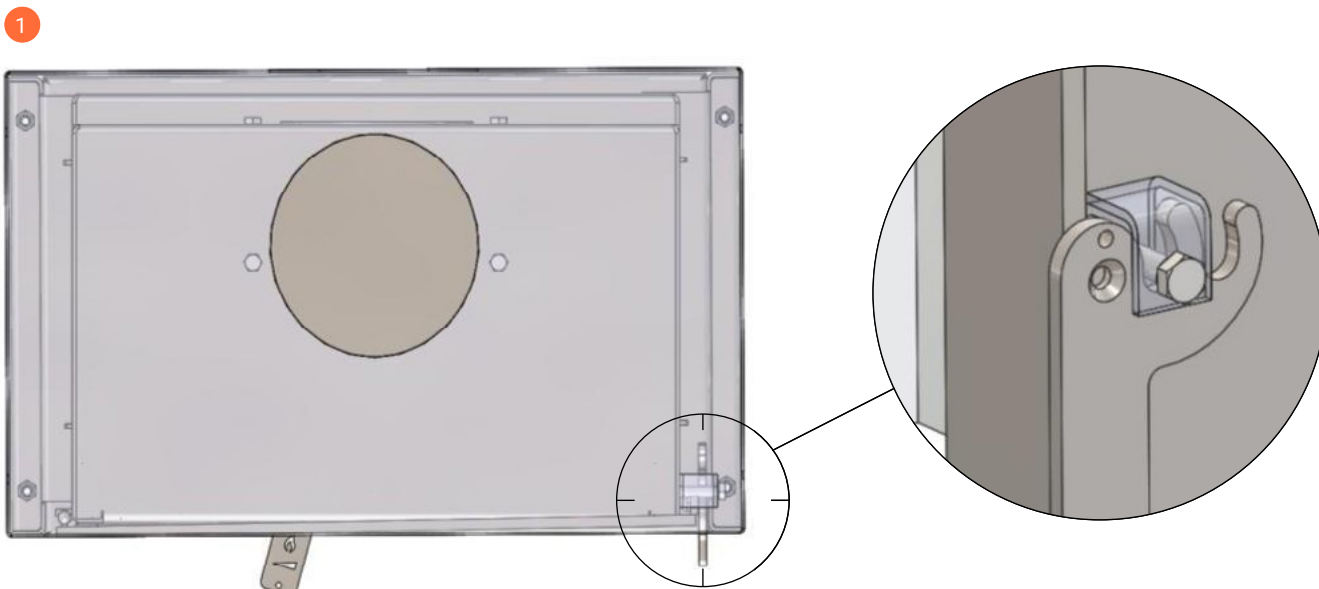

Appendix 3 BAFFLE AND EFFICIENCY PLATE

1

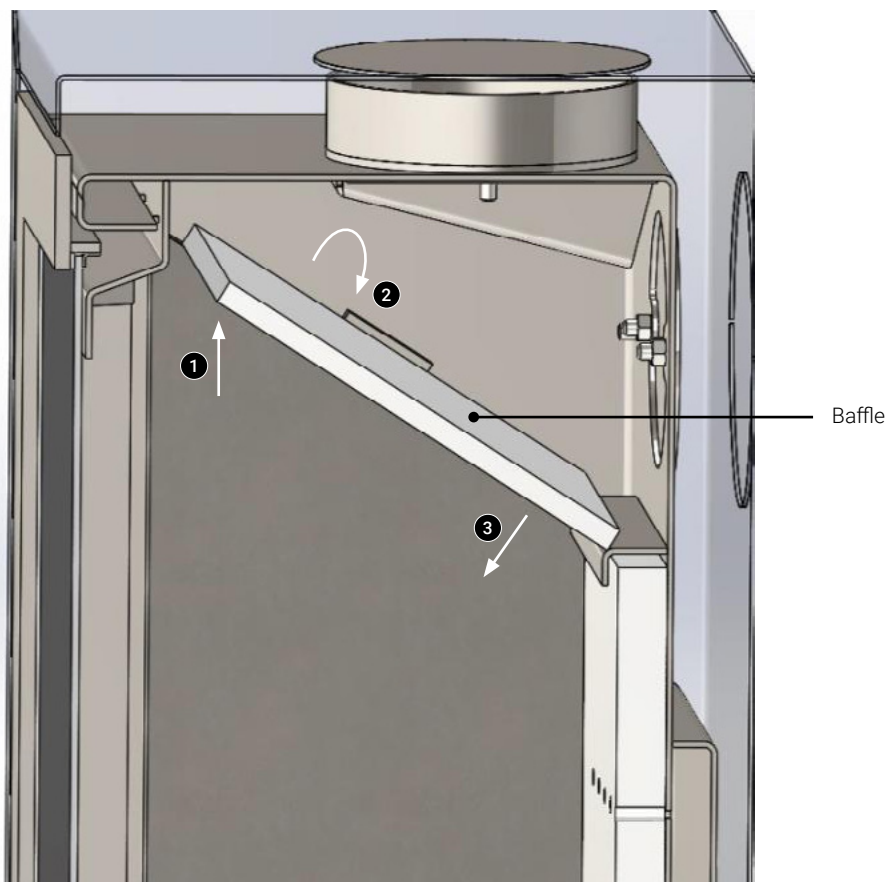

2

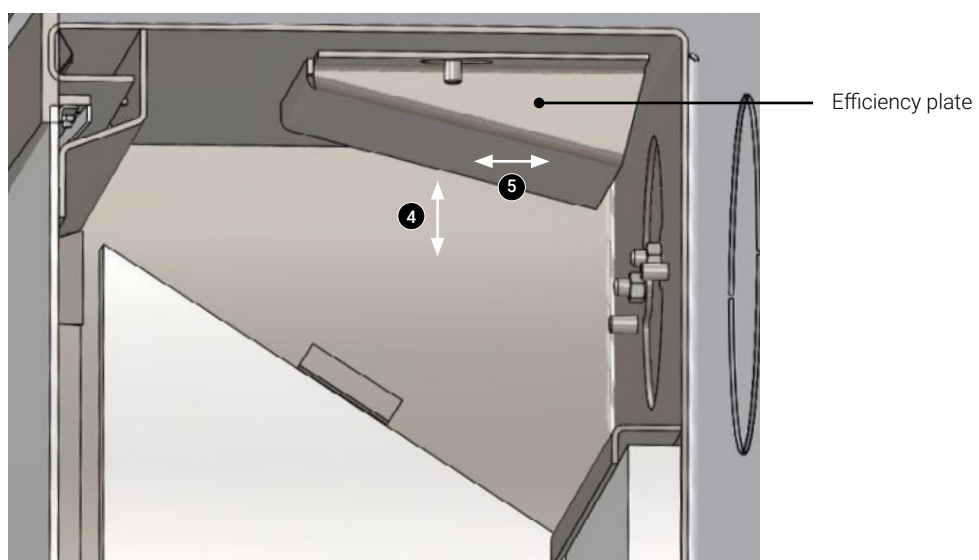

Appendix 4 DIMENSIONAL DRAWING INNER PANELS

